

Demonstration of a Partially Integrated Silicon Photonics ONU in a Self-Coherent Reflective FDMA PON

ECOC 2016 postdeadline

Paper Th.3.C.5

S. Straullu, P. Savio, G. Franco, R. Gaudino, S. Bernabé, M. Fournier, V. Muffato, S. Menezo, B. Charbonnier, E. Temporiti, D. Baldi, G. Minoia, M. Reossi L. Carroll, J. Lee, P. O'Brien, R. Marchetti, G. Duan, F. Saliou and S. Abrate



EU STREP project - FP7-ICT-2011-8

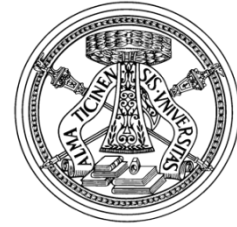

8 partners



FDMA Access By Using Low-cost Optical Network Units in Silicon photonics



The project started in October 2012 and ended last Friday!



The proposed Passive Optical Network (PON)

- Electrical FDMA in both US and DS
- A higher level of multiplexing using WDM
- Targeting bit rate per wavelength well above 10 Gbps

- For time limitation, this presentation focus only on the upstream, that is characterized by:
 - reflective modulation at ONU
 - No need for tunable lasers at ONU
 - Implemented using an ad-hoc silicon photonic chip

 - self-coherent detection at OLT
 - Implemented in real-time on an FPGA platform

The system concept for the upstream

- The required upstream wavelengths are generated at the Central Office by CW lasers and sent downstream
- Each ONU:
 - Selects one wavelength
 - Modulates it in reflection using electrical QAM over a given electrical subcarrier
- The OLT receives all the Frequency Division Multiplexed signals with a self-coherent receiver

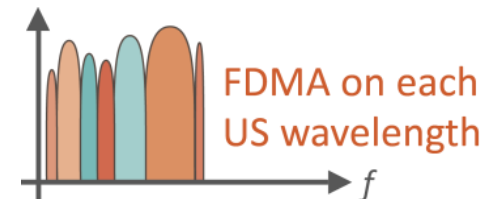
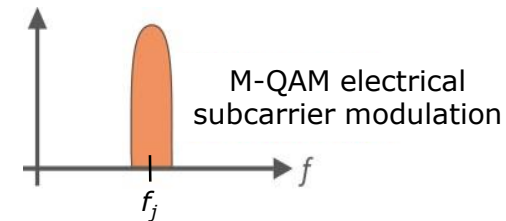
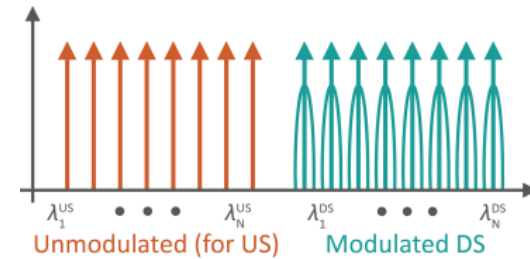

An R-ONU suitable for Silicon Photonic

The ONU effects the projected signal, integrates the (ONU carrier SiM) and performs 90° Faraday rotation (allowing single pol. RX)

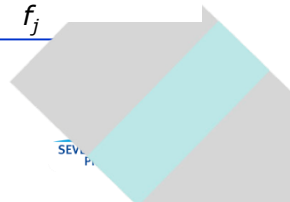
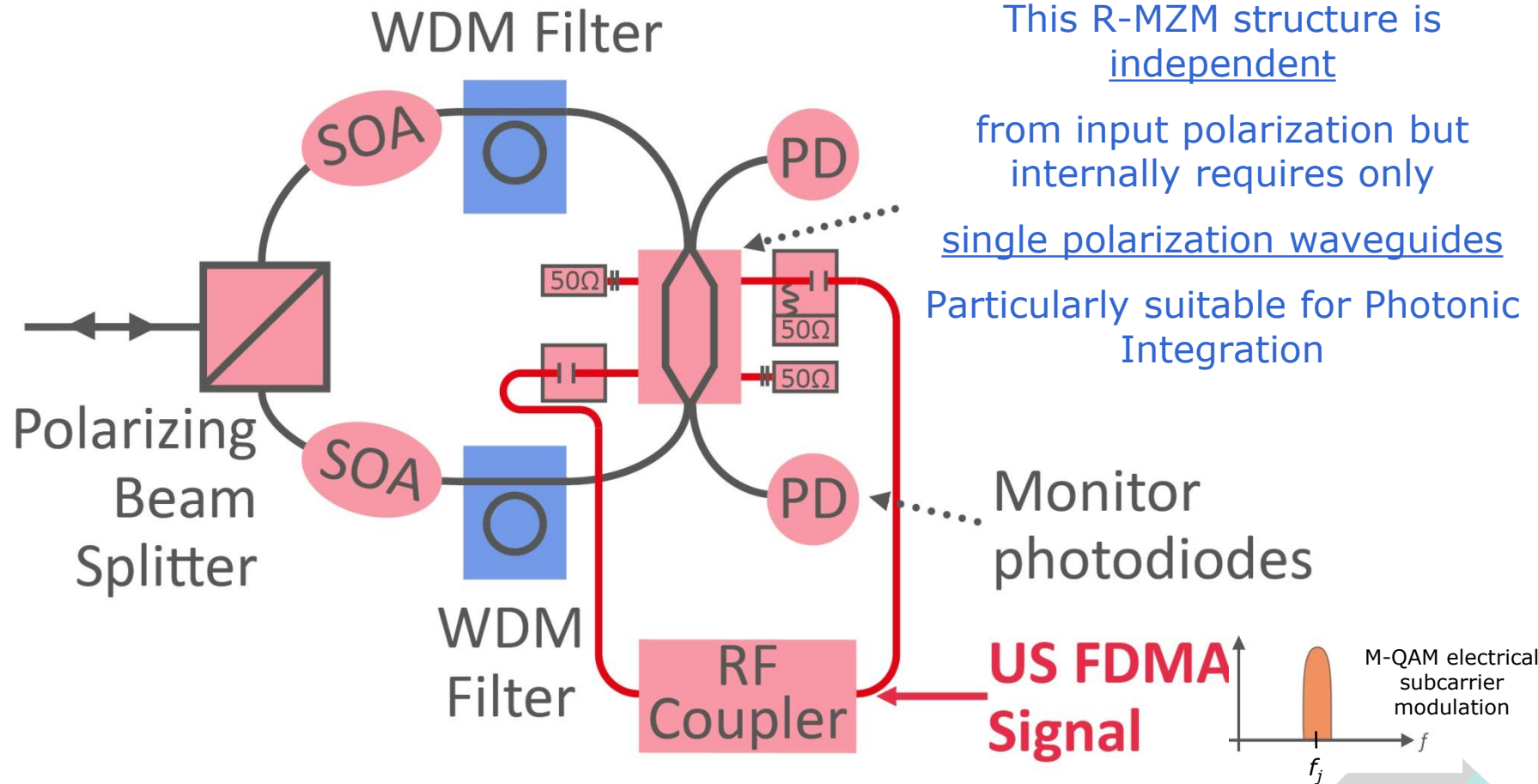

Optical Distribution Network (ODN)

- ITU-T compliant ODN
- Splitter-based PON
- Targeting high ODN losses

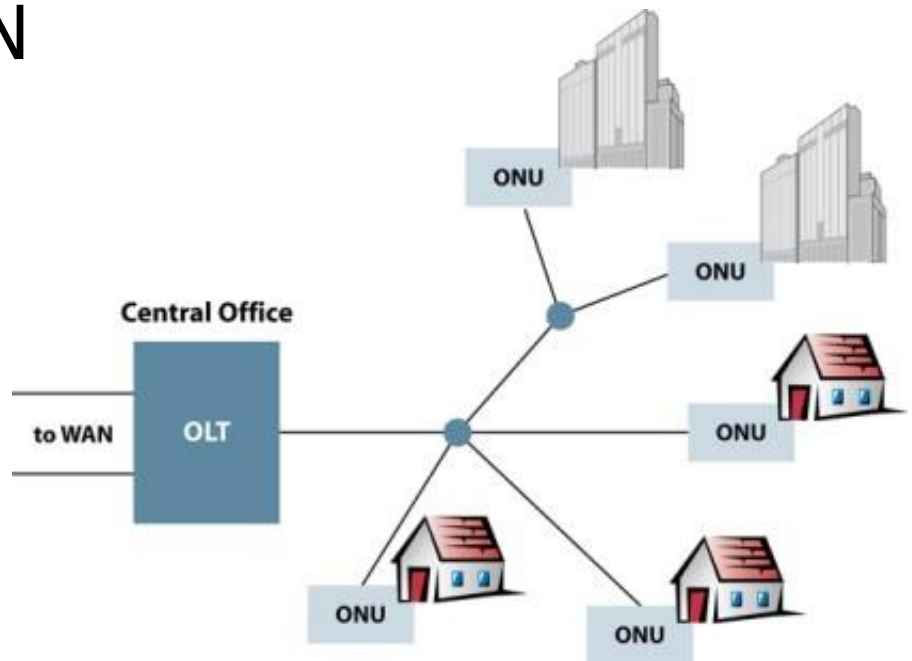

- Compared to ITU-T and IEEE standards our proposal is thus:
 - “in the mainstream” for the ODN
 - “highly alternative” for the ONU and OLT

PROs AND CONs vs. TWDM-PON (NG-PON2)



PROs

Most of WDM complexity and cost left at the OLT

No tunable lasers at ONU and thus NO uncontrolled wavelength problems at ONU switch-on

Continuous data-stream, no burst mode thanks to FDMA

Thus strong FEC, M-QAM and DSP easier compared to burst-mode systems
Higher bit rate per wavelength

Using electrical frequency up/down converters
DSP can work at low sampling rate at baseband



CONs

Modulator and tunable optical filter and SOA at the ONU

Need for a [photonic integrated chip](#)

Linear optoelectronics at both TX and RX

DSP-based, so that DAC and ADC required

BENCHMARKING WITH COMMERCIAL AND DISCRETE OPTOELECTRONIC COMPONENTS

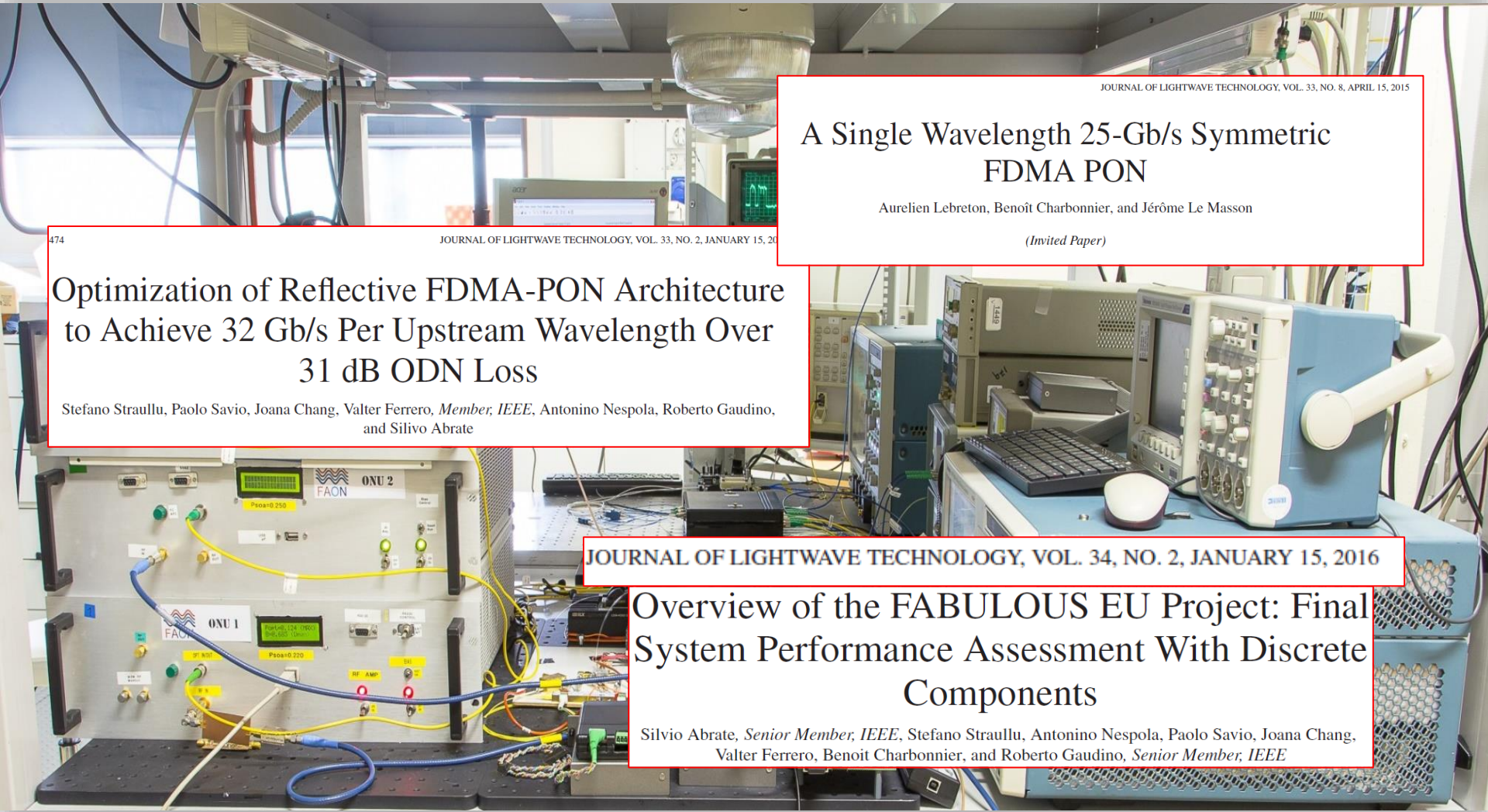

JOURNAL OF LIGHTWAVE TECHNOLOGY, VOL. 33, NO. 8, APRIL 15, 2015

A Single Wavelength 25-Gb/s Symmetric FDMA PON

Aurelien Lebreton, Benoît Charbonnier, and Jérôme Le Masson

(Invited Paper)

JOURNAL OF LIGHTWAVE TECHNOLOGY, VOL. 33, NO. 2, JANUARY 15, 2015

474

Optimization of Reflective FDMA-PON Architecture to Achieve 32 Gb/s Per Upstream Wavelength Over 31 dB ODN Loss

Stefano Straullu, Paolo Savio, Joana Chang, Valter Ferrero, *Member, IEEE*, Antonino Nespola, Roberto Gaudino, and Silivo Abrate

JOURNAL OF LIGHTWAVE TECHNOLOGY, VOL. 34, NO. 2, JANUARY 15, 2016

Overview of the FABULOUS EU Project: Final System Performance Assessment With Discrete Components

Silvio Abrate, *Senior Member, IEEE*, Stefano Straullu, Antonino Nespola, Paolo Savio, Joana Chang, Valter Ferrero, Benoît Charbonnier, and Roberto Gaudino, *Senior Member, IEEE*

BENCHMARKING WITH DISCRETE COMPONENTS

Modulation format	Electrical bandwidth per channel	Net bit-rate per user	Maximum ODN loss
64-QAM	660 MHz	3 Gbps	23.0 dB
64-QAM	1320 MHz	6 Gbps	23.0 dB
16-QAM	330 MHz	1 Gbps	31.0 dB
16-QAM	1650 MHz	5 Gbps	30.5 dB
16-QAM	3300 MHz	10 Gbps	30.0 dB
QPSK	1650 MHz	3 Gbps	23.0 dB
QPSK	3300 MHz	6 Gbps	23.0 dB
BPSK	330 MHz	1 Gbps	31.0 dB
OOK	6250 MHz	5 Gbps	30.5 dB

32 users per lambda
=32 Gbps US per lambda

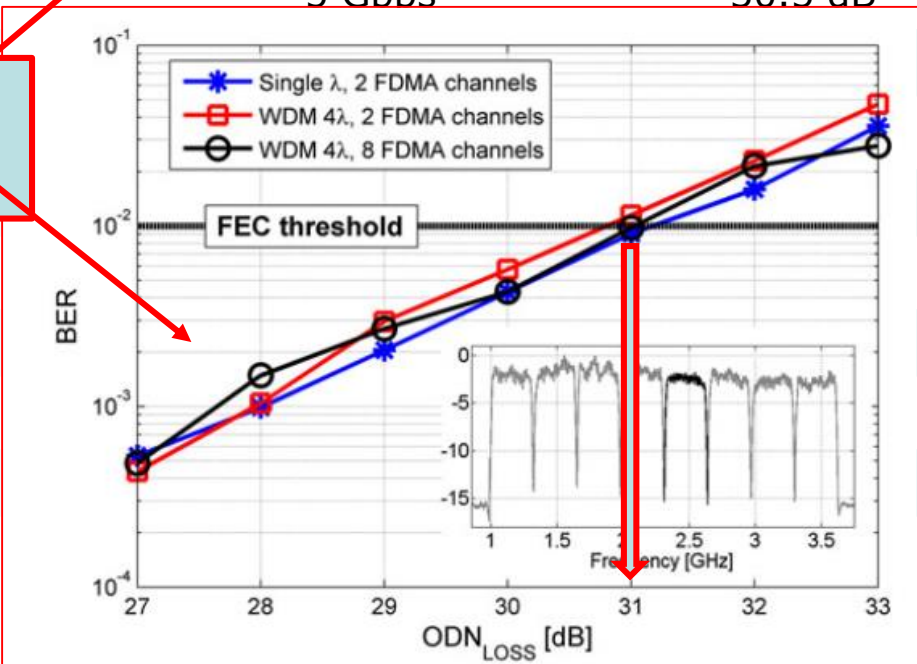
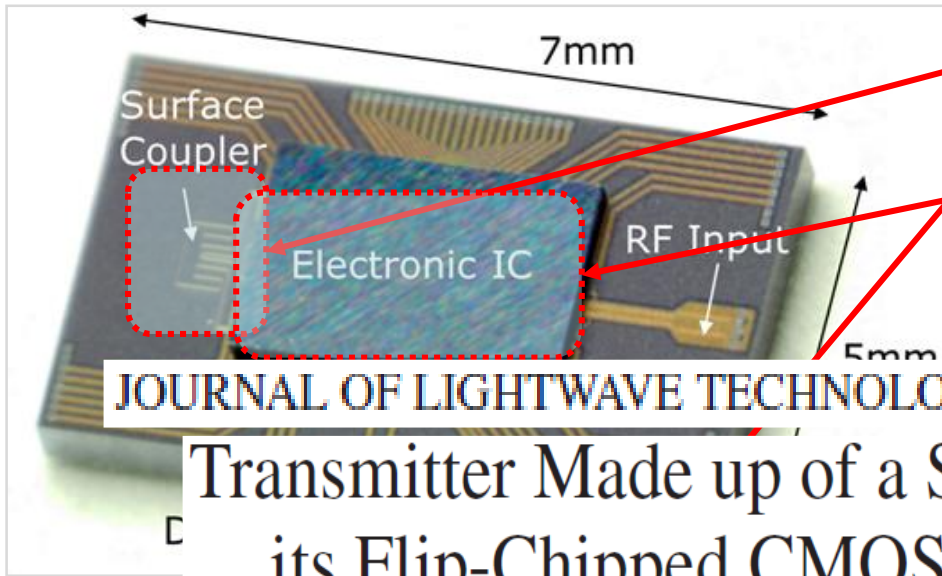

Fig. 2. Performance of the upstream transmission in terms of BER vs ODN loss with two active ONUs (32 emulated channels per wavelength using optical noise loading). It is evident that the simplified setup totally emulates the meaningful interferences.



THE INTEGRATED R-MZM IN SILICON PHOTONICS



- Grating coupler with PBS
- Segmented MZ modulator
- CMOS electrical driver flip-chipped on top
- Low driving voltage and power

JOURNAL OF LIGHTWAVE TECHNOLOGY, VOL. 34, NO. 10, MAY 15, 2016

Transmitter Made up of a Silicon Photonic IC and its Flip-Chipped CMOS IC Driver Targeting Implementation in FDMA-PON

Sylvie Menezo, *Member, IEEE*, Enrico Temporiti, Junsu Lee, Olivier Dubray, Maryse Fournier, Stéphane Bernabé, *Member, IEEE*, Daniele Baldi, Benjamin Blampey, Gabriele Minoia, Matteo Reposi, André Myko, Sonia Messaoudène, Lee Carroll, Silvio Abrate, *Member, IEEE*, Roberto Gaudino, *Senior Member, IEEE*, Peter O'Brien, and Benoit Charbonnier

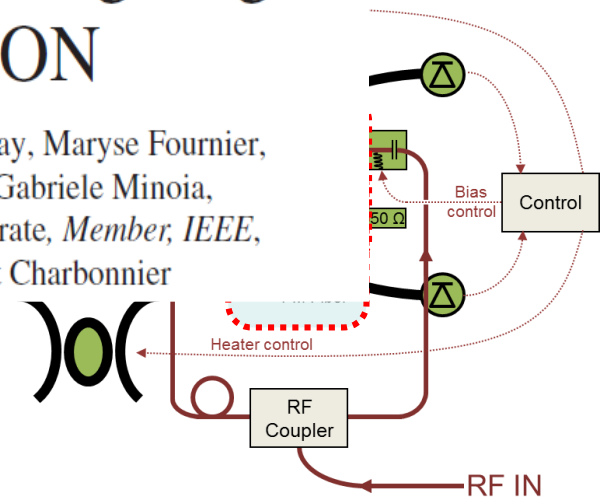
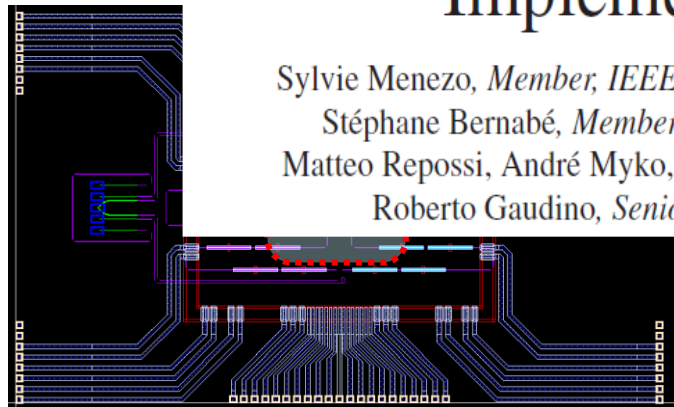

R-MZM Fully-packaged for system tests and demo

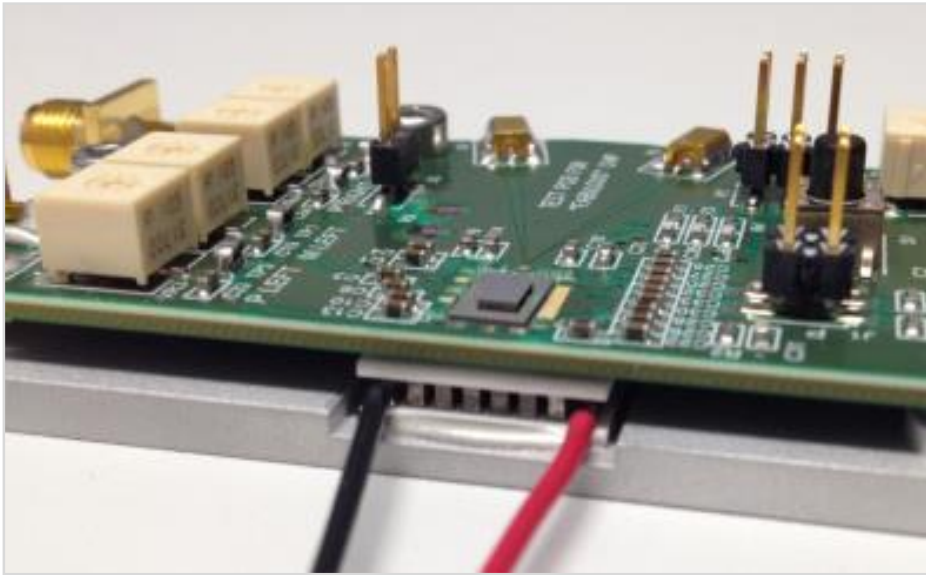

Integrated on a test-board for system experiments
with an external SOA placed before the chip

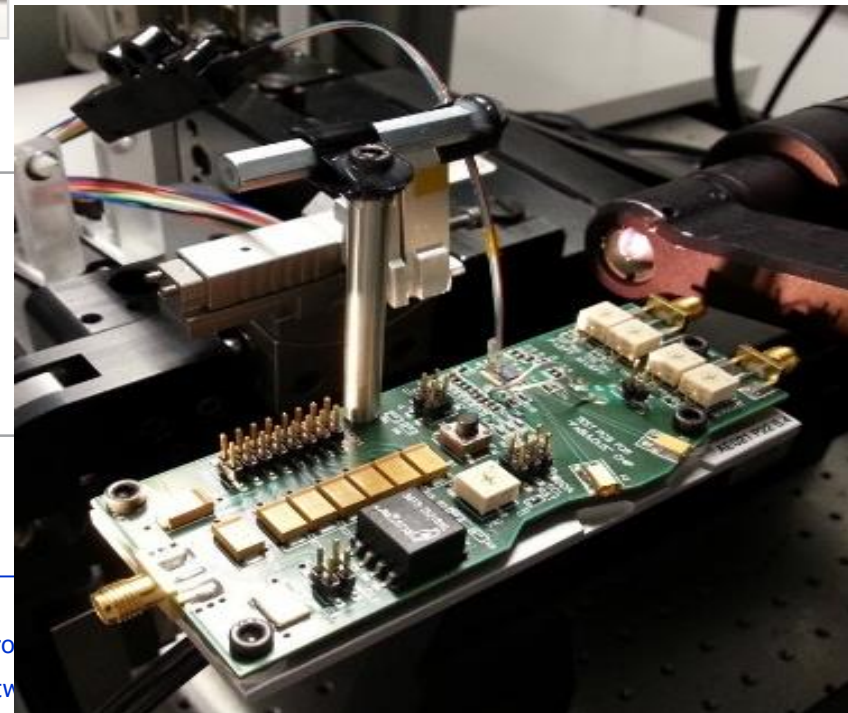

16QAM BACK-TO-BACK at 1Gbps per user

Sampled Demod Output (2 SpS)

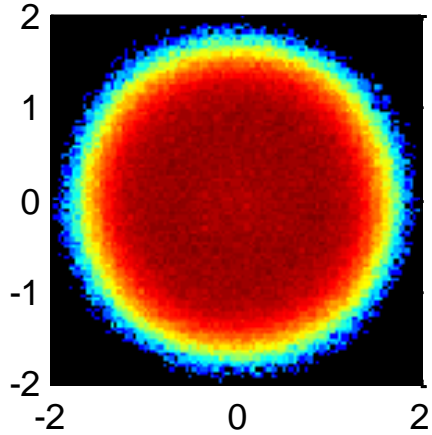

Equalized Signal (Blind Equalizer)

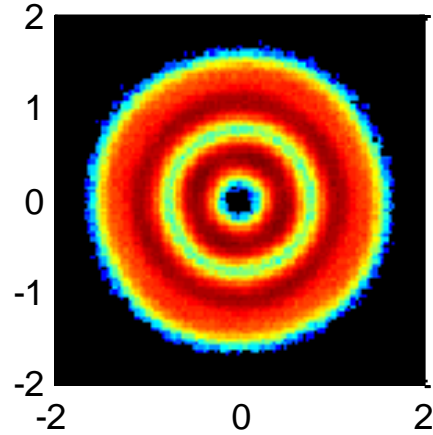

- $f_{ch} = 2\text{GHz}$
- Back-to-back
- EVM = 11%
- BER = $2 \cdot 10^{-3}$

Signal after CPE

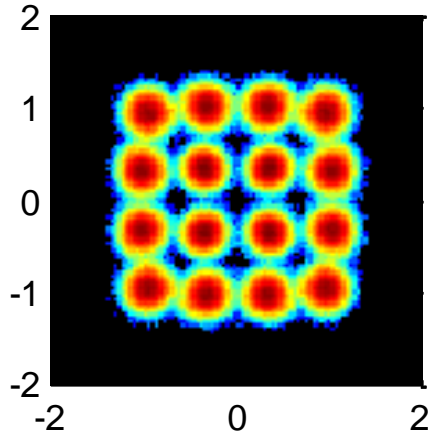

Normalized PSD [dB/Hz]

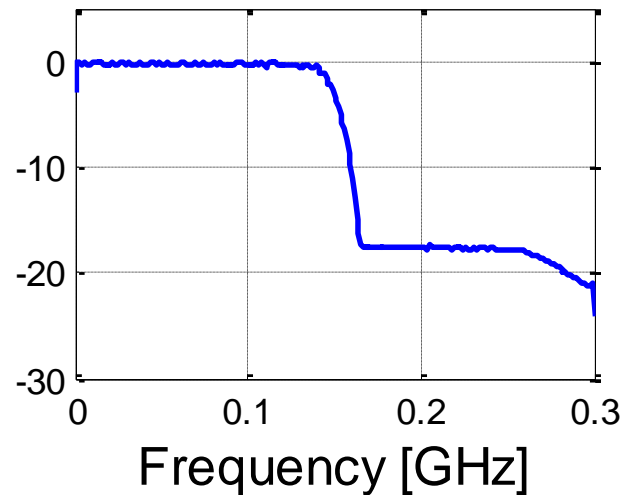

QPSK BACK-TO-BACK at 500 Mbps per user

- $f_{ch} = 2\text{GHz}$
- Back-to-back
- EVM = 12%
- $\text{BER} < 10^{-6}$

Sampled Demod Output (2 SpS)

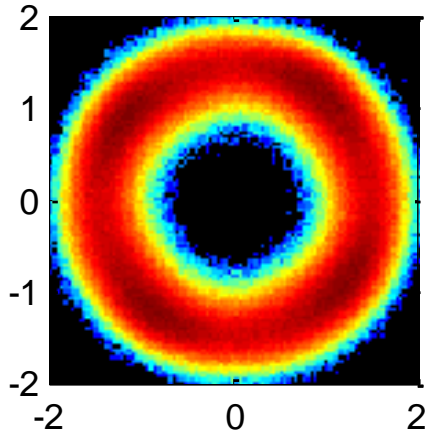

Equalized Signal (Blind Equalizer)

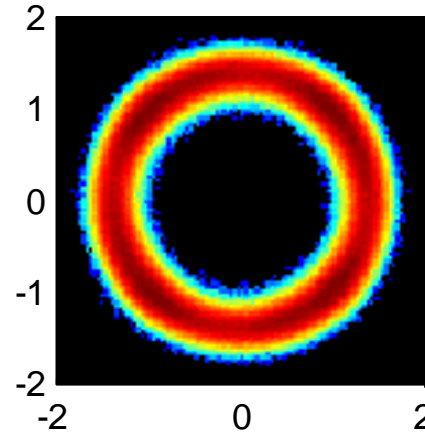

Signal after CPE

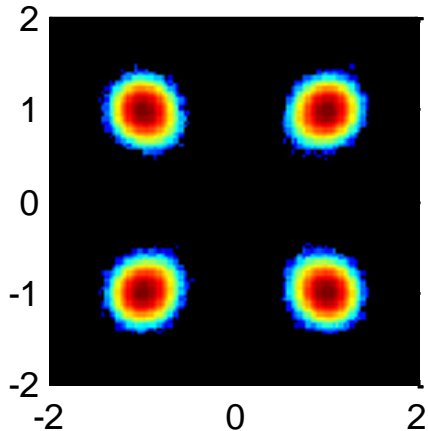

Normalized PSD [dB/Hz]

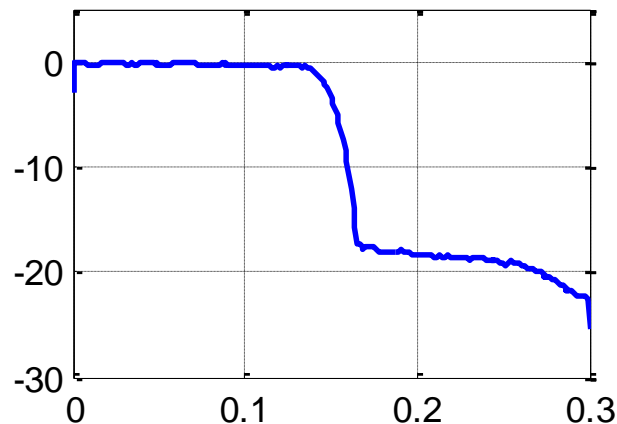

Frequency [GHz]

EXPERIMENTAL SETUP

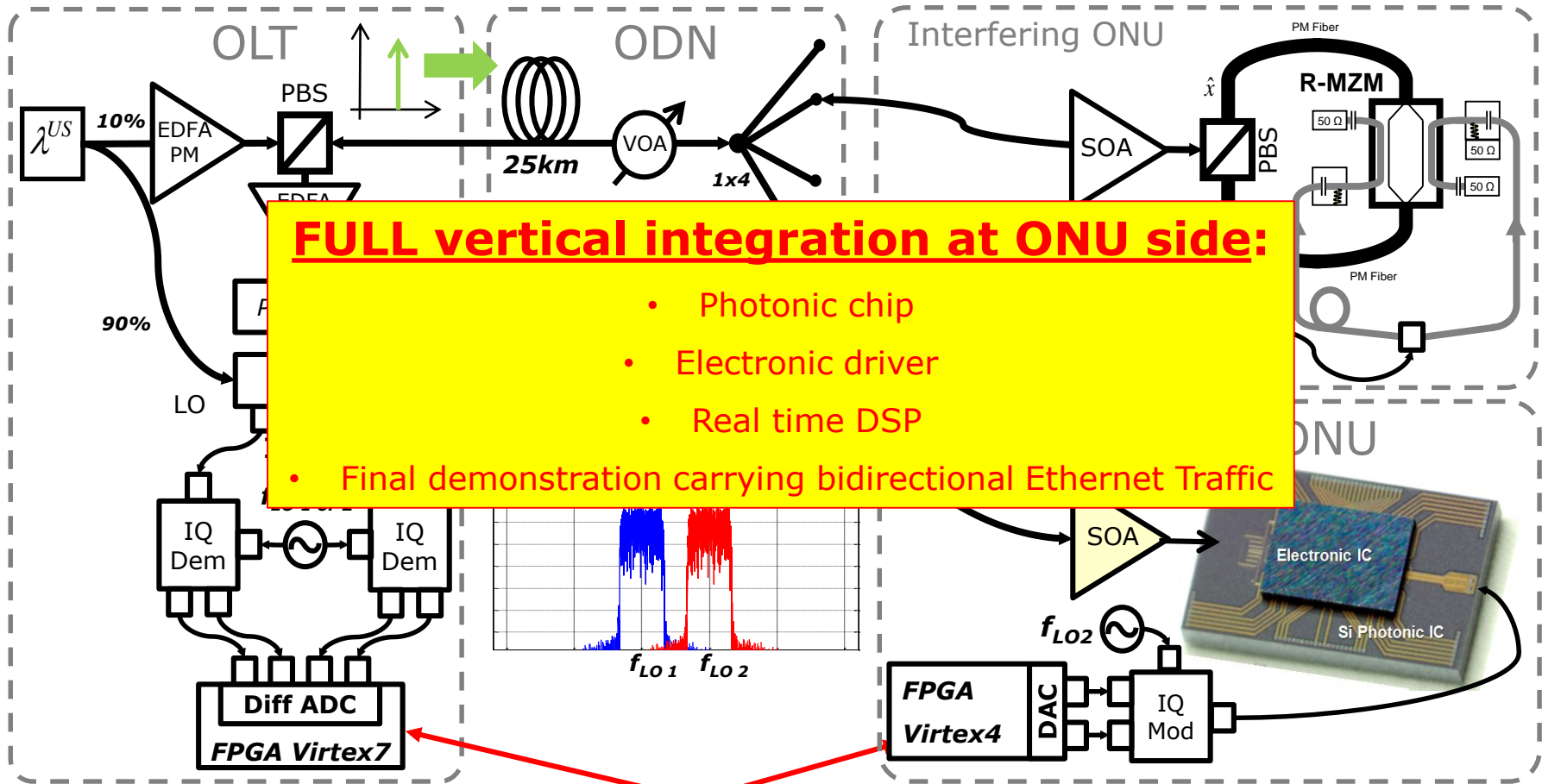

**REAL TIME DSPs programmed on FGPA platforms
XILINX Virtex4 at ONU, Virtex 7 at OLT**

REAL-TIME BER VS. ODN-LOSS

- QPSK
- 500 Mbps
- $f_{ch} = 2\text{GHz}$
- 25 km SMF
- 1550 nm

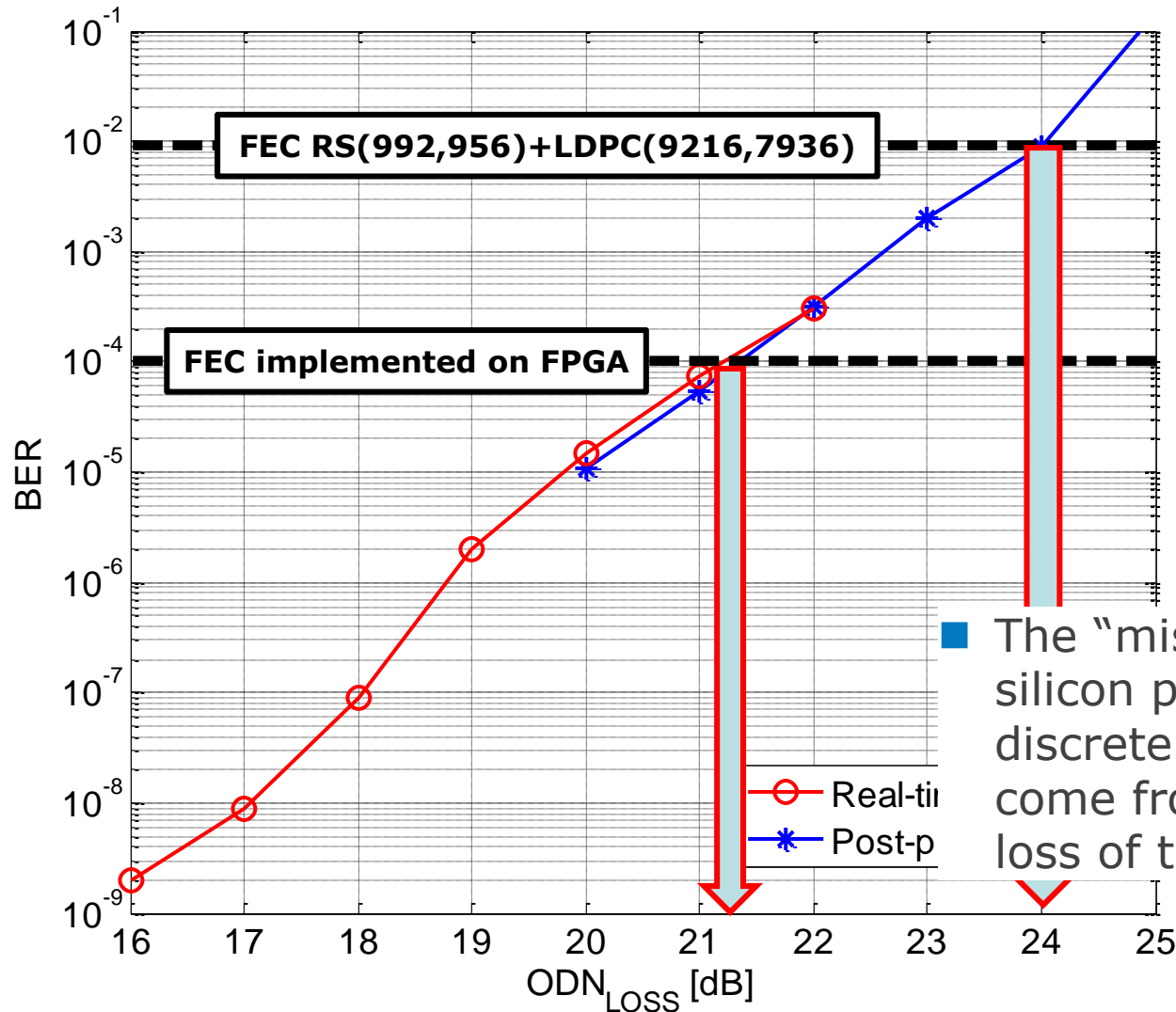

■ The “missing” 7dB between the silicon photonic setup and the discrete components one mostly come from the higher insertion loss of the current prototype

IS THE FULL ONU LOW COST?

Techno-economic study carried out in project.
Considering:

>1.000.000 pieces/year, size of the SiP chip, SOA,
electrical driver, commercial FDM IC

ABOUT 80\$
(70% DUE TO PACKAGING)

Review and comparative assessment of FDMA-PON vs. TDMA-PON
for next-generation optical access networks

Silvio Abrate^a, Roberto Gaudino^{b,*}

Optical Fiber Technology

FDMA-PON and NG-PON2: Performance and Cost Comparison

**Power Consumption Estimation for the Silicon-Photonics
Reflective ONU Conceived within the FABULOUS
European Project**

Papers presented at
ICTON 2015



Some of the techno-economic figures
were taken from the EU project OASE

<http://www.ict-oase.eu/>

Conclusion

We have demonstrated



the effectiveness of a self-coherent reflective FDMA PON architecture in complying to ODN loss standard requirements



the feasibility of the required Photonic Integrated Circuits and Real time DSP

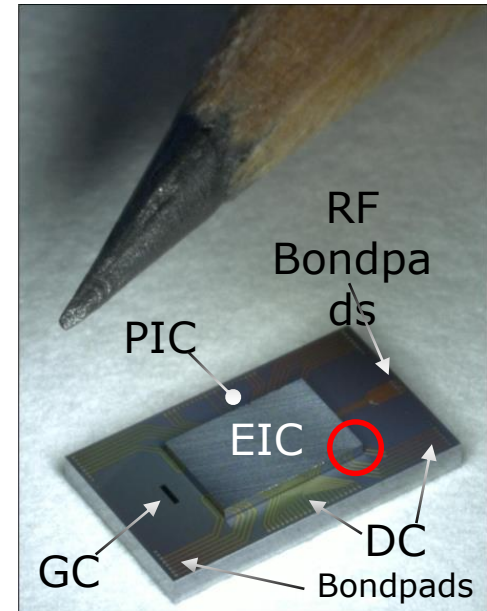

Low cost ONU



R-ONU with travelling wave MZM and two SOAs expected in 6 months

ACKNOWLEDGMENTS

The research leading to these results has received funding from the European Community's Seventh Framework Programme FP7/2007-2013 under grant agreement n°318704, titled:



FABULOUS:
"FDMA Access By Using Low-cost Optical Network Units in Silicon Photonics"



WEB site:

www.fabulous-project.eu



To contact us:

info@fabulous-project.eu
roberto.gaudino@polito.it



BACKUP SLIDES

PIC FABRICATION



- Processed at CEA-LETI clean room
- 200 mm wafers (8 inches)
- Used Substrate : HR-SOI with 2 μ m Buried Oxide and 220 nm Silicon
- Devices E/O characterizations on Cascade Elite wafer probers

Couplers

- ▶ footprint < 500 μ m²

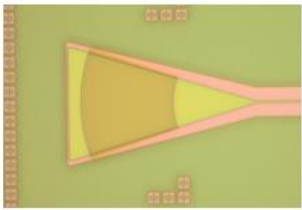

Heater R: 2,2 K ohms

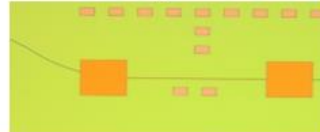

Waveguide Specifications

- ▶ propagation loss < 1.2 dB/cm

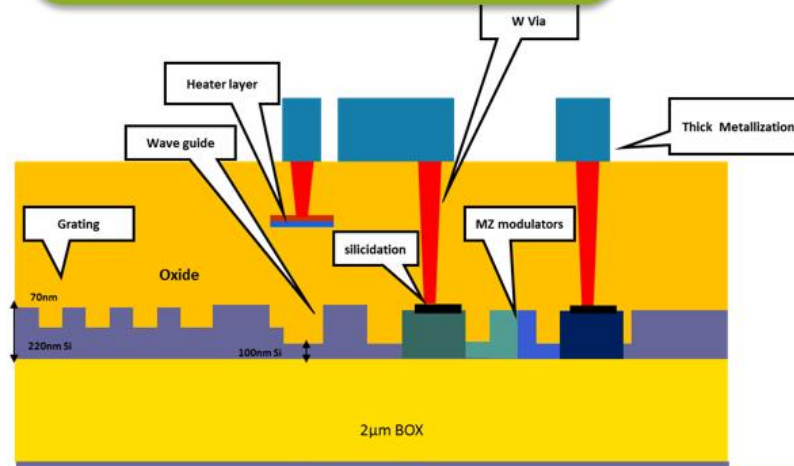

- Grating Coupler etching
- PN junction implantation
- Rib waveguide etching
- Heater & via
- Electrodes

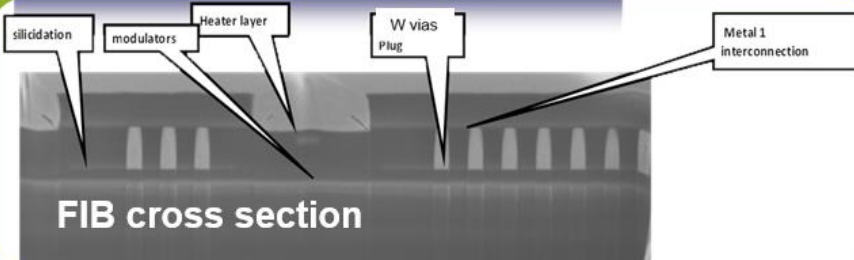

Mach Zehnder modulators

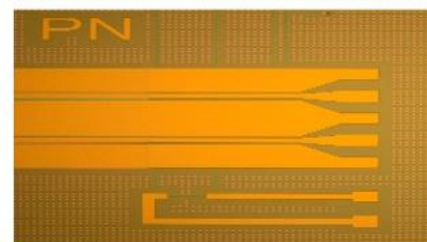

Electronic driver flip-chip processed on the Silicon Photonic platform

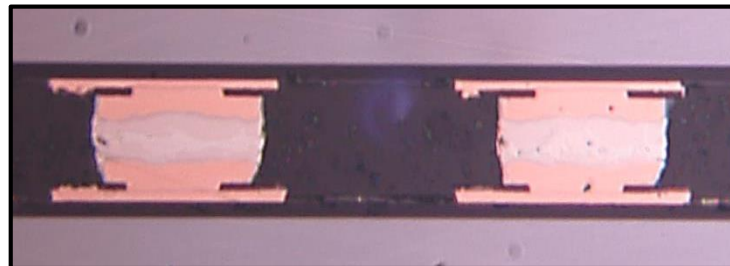
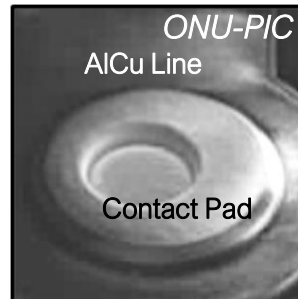
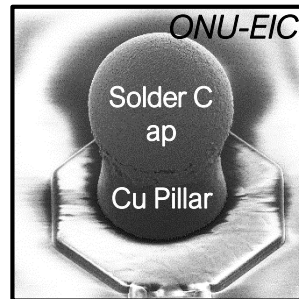

20 μm Copper Pillar
SnAgCu Solder Cap

SIMPLIFIED COHERENT DETECTION

Faraday rotation at ONU allows simplified coherent detection at the OLT

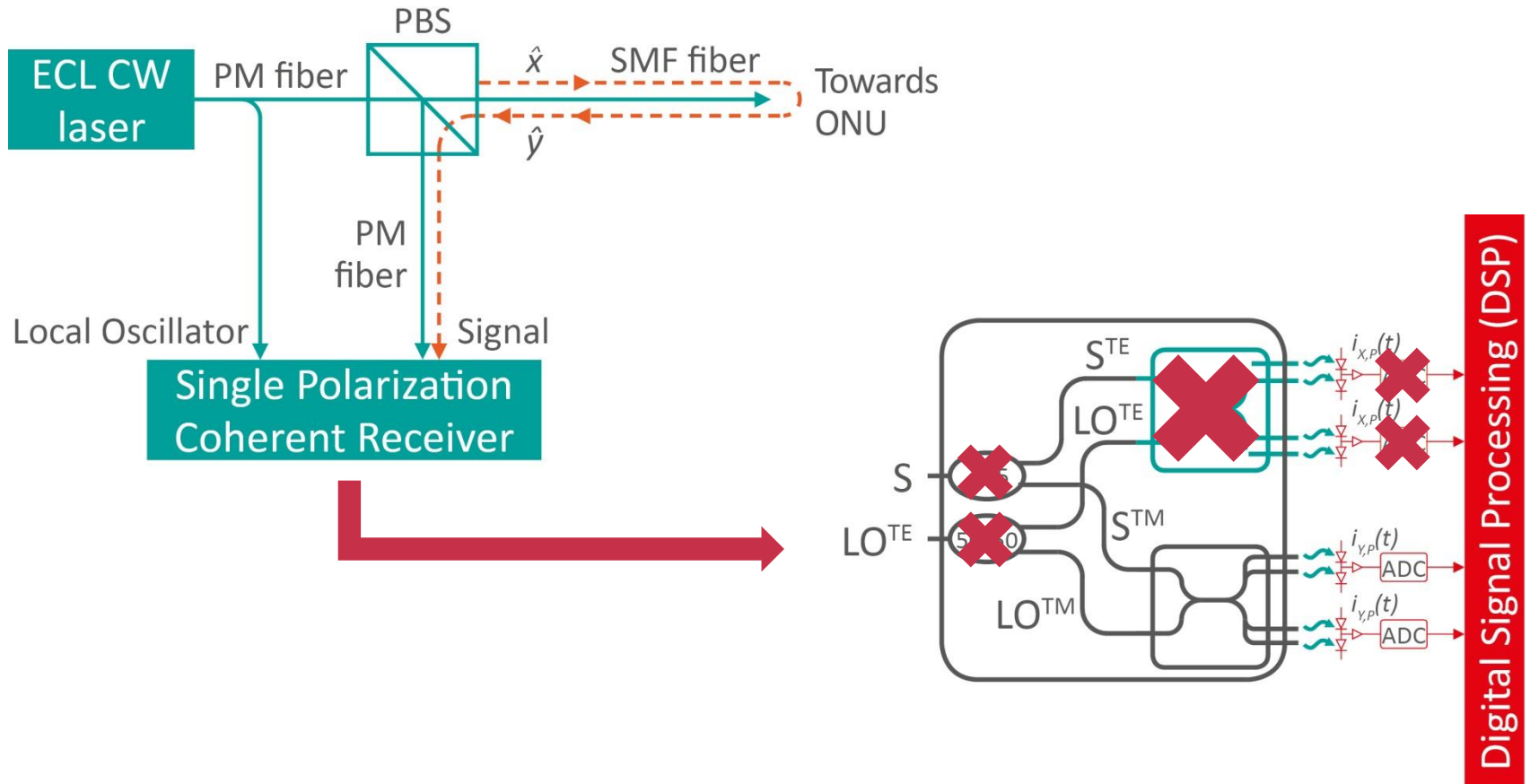

System experiments using discrete optoelectronics

■ Main achievements for what concerns 1 Gbps per user experiments

- 32 Gbps per wavelength for 32 users
- Up to 31 dB of ODN loss
- Demonstration of four-lambdas WDM

- A joint demo including both Orange Labs and ISMB hardware prototypes was performed. The experimental setup with

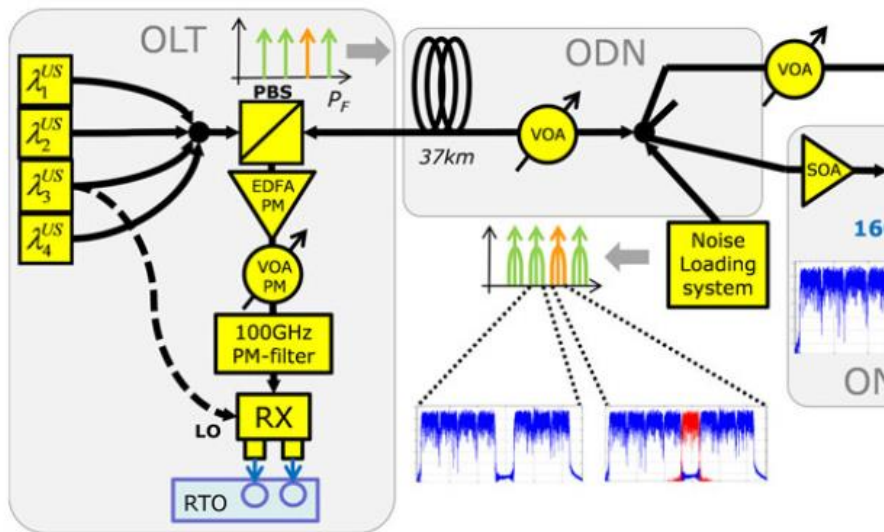

Fig. 1. Full off-line processing experimental setup with installed fiber, two active ONUs and a variable optical amplifier, RTO: real time oscilloscope, SOA: semiconductor optical amplifier, ABM: amplitude beam modulator, REAM: reflective electro absorption modulator).

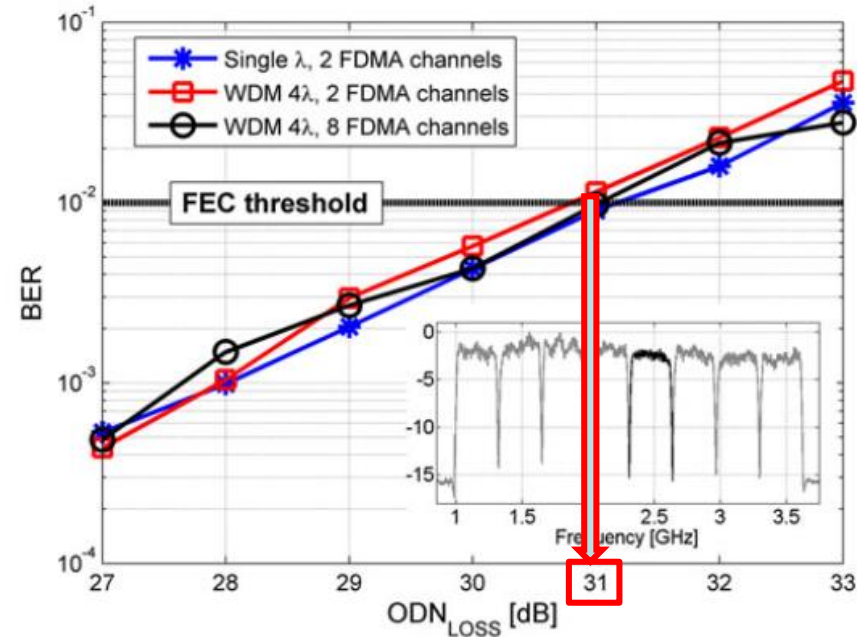

Fig. 2. Performance of the upstream transmission in terms of BER vs ODN loss with two active ONUs (32 emulated channels per wavelength using optical noise loading). It is evident that the simplified setup totally emulates the meaningful interferences.

ONU power consumption

Device	Power consumption [W]
Electronic chipset for modulation (Rx and Tx)	1.1
Optoelectronic receiver	1.0
R-MZM driver	1.4
Photonic integrated circuit (R-MZM)	0.5
SOA	0.5
Tuneable optical filters	0.5
TEC	3
TOTAL	8 Watt

6 Watt new estimation

Post-deliverable news: the actual required power for the TEC in the final release of the PIC is significantly less

- The new estimate is 1 W to stabilize the PIC to 25 C
- The total power consumption of the ONU would thus decrease to 6 W

Bill-of-Material costs: two scenarios

SCENARIO #1: Medium-term scenario in which the NG-PON implementation is based on TWDM-PON using 4 wavelengths per direction for an aggregated capacity of 40 Gbps DS and 10 Gbps US

	FABULOUS		TWDM PON	
	OLT	ONU	OLT	ONU
Cost	1620 US\$	78 US\$	5150 US\$	625 US\$
Power consumption	88 W	8W	89 W	10 W

SCENARIO #2: Long-term scenario in which the NG-PON implementation is based on TWDM-PON using 16 wavelengths per direction for an aggregated capacity of at least 160 Gbps DS and 40 Gbps US

	FABULOUS		TWDM PON	
	OLT	ONU	OLT	ONU
Cost	6026 US\$	78 US\$	19100 US\$	625 US\$
Power consumption	329 W	8 W	281 W	10 W